

SKYSTREAM HYBRID 6™

INSTALLATION MANUAL NORTH AMERICA EDITION

The installer is solely responsible for complying with all applicable building and electrical codes.

To help prevent stainless steel hardware from seizing together (1) apply anti-seize lubricant to bolts, (2) keep hardware shaded prior to installation, and (3) slowly fasten nuts during installation.

Southwest Windpower, Inc.
1801 West Route 66
Flagstaff, Arizona 86001
Phone: ++ (1) 928 - 779 - 9463
Fax: ++ (1) 928 - 779 - 1485

www.windenergy.com



MADE IN THE **USA** © January 2012 Southwest Windpower, Inc.
All Rights Reserved

TABLE OF CONTENTS

IMPORTANT SAFETY INSTRUCTIONS _____	5
SEQUENCE AND OVERVIEW OF INSTALLATION STEPS _____	6
TOWER RING INSTALLATION _____	8
TAPERED RING AND GEAR INSTALLATION _____	10
SUPPORT SHELL INSTALLATION _____	11
CROSS ARM STRUCTURE ASSEMBLY AND INSTALLATION _____	13
MOTOR/GEARBOX INSTALLATION _____	14
ALIGNMENT AND CHAIN INSTALLATION _____	14
SOLAR PANEL AND MICRO-INVERTER INSTALLATION _____	16
FINAL CABLE CONNECTIONS _____	18
APPENDIX A: ELECTRICAL DIAGRAMS _____	21

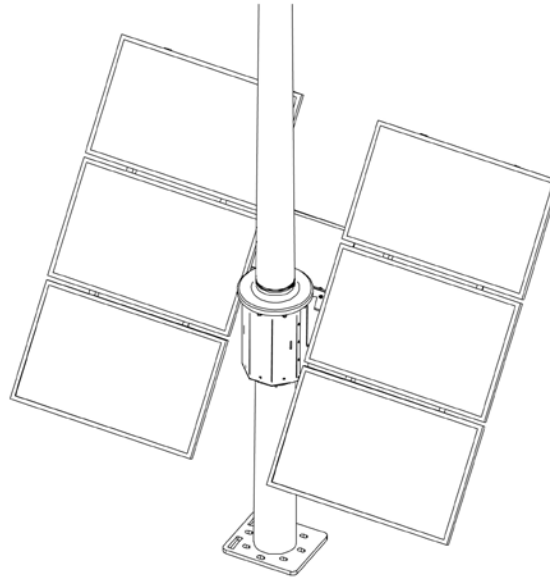

The hybrid energy sun tracker is delivered in two packages. One pallet contains the shell assemblies and three boxes of hardware. The boxes of hardware are packaged inside of the shell assemblies. The second package will be a 6" X 6" x 11' box containing four rails and brackets, as well as the cable support.

IMPORTANT SAFETY INSTRUCTIONS

READ THESE INSTRUCTIONS IN THEIR ENTIRETY BEFORE INSTALLING OR OPERATING.



PROFESSIONAL INSTALLATION: Southwest Windpower strongly recommends Skystream Hybrid 6™ be installed by trained professionals. Proper installation is required to maintain your warranty.

GENERAL INSTRUCTIONS

- 1) **SAVE THESE INSTRUCTIONS.** This Owner's Manual and the associated Owner's Manual contain important instructions that must be followed during installation, maintenance, and use.
- 2) The Skystream Hybrid 6™ system uses and generates high voltage AC and DC electricity that could cause major injury or death. As a result, only trained personnel should work on the system. Observe safety precautions at all times. Use "Lock-Out" and "Tag-Out" procedures during servicing to prevent unintended exposure to electricity.
- 3) The Hybrid 6™ system includes exposed and moving parts that move periodically and unexpectedly. As a result, access to the Skystream Hybrid 6™ system must be restricted. Systems that are mounted at heights within reach of individuals should be fenced to avoid interference, injury, or collisions by passing individuals or equipment. Systems should also be fenced or otherwise restricted if there is a risk of uninformed people climbing or using ladders to touch or disturb the system.
- 4) The Skystream Hybrid 6™ must be mounted at heights that comply with all local building codes and that are within the structural capabilities of the tower. The maximum clearance (height) from the surface of the lower tower flange (at the foundation) to the lower edge of the solar panel array is as specified in the table below. If in doubt, consult your dealer or Southwest Windpower

Tower	Maximum Clearance (Height) Between Lower Tower Flange and Lower Edge of Solar Panel
SWWP 45-19 "Standard"	4 feet (1.2m)
SWWP 45-19 HD (Heavy Duty)	8 feet (2.4m)

- 5) Properly complete and return all warranty registration cards. Failure to do so may affect your warranties.
- 6) Do not use unauthorized fasteners. Use fasteners supplied with the Hybrid 6™ system.
- 7) Maintain tightness of fasteners according to torque requirements (see Maintenance and Inspections).

INSTALLATION INSTRUCTIONS

1. Installation must be performed by trained personnel who are familiar with and capable of handling heavy mechanical equipment and high voltage AC and DC electricity.
2. Always obtain a building permit prior to construction.
3. Skystream Hybrid 6™ must be installed in accordance with the Skystream Hybrid 6™ Installation Manual and local and national building codes. Failure to do so will affect and possibly void your warranties.
4. Installation must be performed in compliance with the National Electric Code (NEC) and all local building codes.
5. Use only proper grounding techniques as established by the NEC as well as electrical disconnect switches, wire sizes and types.
6. Install the Skystream Hybrid 6™ system on a calm day with negligible wind at ground level. Solar panels will experience strong forces in windy conditions.
7. Use proper hydraulic hoists, cranes, or other lifting equipment to safely lift Skystream Hybrid 6™ components or systems.
8. Always wear appropriate protective personal equipment such as closed toe work shoes, hard hat, work gloves, and safety glasses when working on or installing the Hybrid 6™ system.
9. The Skystream Hybrid 6™ system complies with international safety standards. Therefore, the design and its installation must never be compromised:
 - a. Do not open inverter covers. Doing so without factory authorization will void the warranty.
 - b. Apply the proper torque to all fasteners.
 - c. Install only on a Professional Engineer (PE) certified tower.
10. Skystream may only be installed on a tower approved by Southwest Windpower for use with the Skystream Hybrid 6™ system. Do not install Skystream Hybrid 6™ on roofs or unauthorized towers.
11. Do not use unauthorized fasteners. Use fasteners supplied with Skystream Hybrid 6™.

SEQUENCE AND OVERVIEW OF INSTALLATION STEPS

Installation of the PV tracker portion of the Skystream Hybrid 6™ system includes the following basic sequence of steps. Please refer to the relevant manual for each step – for example, the tower and hinge plate/gin pole system has its own installation manual, as does the Skystream 3.7™ wind generator.

1. Properly locate/site the Skystream Hybrid 6™ system. Proper site selection requires consideration of the system's access to both clear flow wind and to un-shaded sun. Other considerations include access to the site, the wire run path between the system and the electrical connection point, and safety hazards.

For the Skystream Hybrid 6™ system to function properly and to its full potential, the system must be installed in a location with suitable wind and solar energy potential. Wind turbulence sources must be avoided, as should any potential source of solar shading. Consideration must be given to both current and future conflicts, such as mature tree height or future construction plans. Please refer to both the Skystream 3.7™ and the Skystream Hybrid 6™ Owner's Manuals for important information.

2. Install an appropriate tower foundation, grounding electrode, and electrical wiring or conduit. Please refer to the appropriate tower and foundation manuals for sizing information and foundation drawings. In most cases, your local AHJ (Authority Having Jurisdiction) will require a "wet stamped" set of foundation plans. A "wet stamped" plan is reviewed and stamped, with an original seal, by a PE (Professional Engineer) who is licensed in your state or province. As they are jurisdiction specific, Southwest Windpower does not provide these "wet stamped" plans but they can be obtained from Tower Engineering Professionals or a qualified local PD.

In most cases, a sub-panel must be installed at or near the base of the tower. The installer should make provisions for this sub-panel in both the wire/conduit routing and in providing a suitable support for the sub-panel. From this sub-panel, wiring or conduit must be run in the shortest practical path to a suitable electrical connection point. In most cases, this connection point will be the main service panel. In any

event, it should be as close as possible to the point where the electrical system of the supplier and the electrical system of the user are connected (the location where service voltage is measured, per ANSI C84.1). Connection of the Skystream Hybrid 6™ electrical wiring to any other point (such as an outbuilding's sub-panel or other remote panel) requires additional analysis of the entire wire run's impedance and, normally, requires increased wire sizes to prevent excessive voltage rise during system operation. This analysis is the responsibility of the dealer/installer, using the services of a qualified electrical engineer or electrician.

3. Assemble the tower, hinge plate and gin pole system, and solar tracker mounting rings (hereinafter referred to as the tower rings). Please refer to the appropriate tower manual for instructions regarding the proper assembly of the tower. A sectional tower which is not properly assembled, using specified compression techniques and forces, may wobble and cause degraded wind turbine performance.

The center opening in the tower rings is large enough to slide over the top flange of a completely assembled 45-19 or 45-19HD tower. But, for convenience, it may be easier to slide them onto the lower section of the tower and weld them in place before assembling the upper sections. A wire pass-through hole must also be drilled in the tower sidewall and it is normally easier to install that before the tower is completely assembled. After welding the rings in place, but before the next step (installing the Skystream 3.7™), the solar tracker top cover must be slid into position. Refer to the detailed instructions, later in this manual, for specific information on this process.

4. While the tower is lying down (but properly supported) assemble, install, and check functionality of the Skystream 3.7™ components (including the Skylevel, cabling, and turbine).
5. Assemble and install the solar tracker drive mechanism, module support rails, PV modules, microinverters, and wiring. The solar tracker can be installed on the tower rings with the tower lying down (but properly supported) or when standing upright, as preferred by the dealer/installer.

In most cases, it will be easier to install the solar tracker before standing the tower upright and the 45-19/45-19HD tower lifting mechanisms are suitable for raising the tower with the Skystream 3.7™ and the solar tracker installed. If the solar tracker is installed on a tower in the upright position, appropriate lifting equipment and worker supports are required.

6. Make final wire connections in the sub-panel at the tower base and at the main connection point, then test the system.

TOWER RING INSTALLATIONS

The Skystream Hybrid 6™ solar tracker drive unit is mounted to the tower on two tower rings, which are tack welded to the tower and which are aligned (during the installation process) with the 3 steel rods of the ring welding alignment jig – Part # 2-SSH-222. The alignment jig is a separate dealer-required item, which is not included with each Skystream Hybrid 6™ system as it is re-used on multiple installations. Do not attempt to install the tower rings without the use of the alignment jig, as the proper spacing and parallel alignment of the rings is critical to the proper operation of the system.

Normally, the following steps would take place with the first tower section attached to the foundation with the hinge plate and while the first tower section is properly supported with cribbing or other suitable and stable support. In some cases, the dealer/installer may elect to perform these steps on a tower which is in the vertical position (such as a retrofit installation) or before the tower sections are transported to the site (if welding equipment is not available at the installation site). In such cases, the following instructions may need to be modified slightly to meet the demands of the altered installation conditions. If the tower rings are welded to the lower tower section before transportation to the site, it is important to protect those rings from damage during transport and installation.

1. From the bottom of the tower's base flange, measure up (towards the upper end of the tower's first section) and mark the North side of the tower with a permanent marker.

For installation on a 45-19HD tower, with 8-feet of clearance between the tower base flange and the lowest point of the PV array, make a mark 154 inches from the bottom of the base flange.

For installation on a 45-19 tower, with 4-feet of clearance between the tower base flange and the lowest point of the PV array, make a mark 106 inches from the bottom of the base flange.

This mark will be used to locate the wire penetration hole.

2. Examine the two tower rings and ensure they have not been damaged or bent during shipping or handling. It is important that the rings are

flat. Note that one ring has a larger inside diameter than the other ring. The ring with the larger inside diameter will be the bottom ring, to accommodate the tapering of the tower.

3. Locate the 3 larger holes drilled in the tower rings – these holes are used for the welding alignment jig during the installation process. Align the three metal rods of the alignment jig between the two tower rings. It is easiest to do this one rod at a time. Using the hardware which came with the jig, bolt the alignment rods into place (utilizing the three holes you identified earlier) so that the tower rings are properly spaced and aligned.
4. Slide the two rings, attached to the alignment jig, over the top of the tower making sure that the ring with the larger inside diameter is oriented closest to the tower base. Push this assembly towards the base of the tower until it is snug and the inside of the tower rings are resting against the sidewalls of the tower. Check the position of the rings relative to the hole mark you made in step 1. The top ring should be about 6 inches below the hole mark you made. If necessary, the inside of the tower rings can be filed or ground slightly to accommodate an out-of-round tower or to position the ring assembly so that there is approximately 6 inches of clearance between the top ring and the hole mark.



5. Using a permanent marker, mark the tower sidewalls at every point where the inside of the upper and lower tower rings contact the tower (on both surfaces of the tower rings). These contact marks will be used to indicate where galvanizing should be ground from the tower to permit welding.

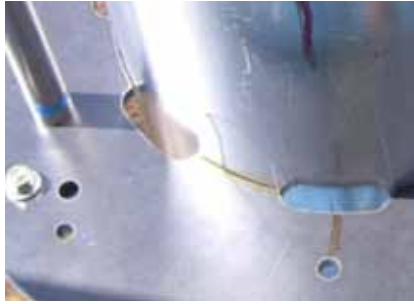

- Slide the jig up, towards the top of the tower, to provide access to the contact marks you just made. Using a suitable grinder, remove the galvanizing from the surface of the tower sidewall at the locations of the contact marks. Remove only enough surface material to permit proper tack welding of the tower rings to the tower.
- Slide the jig and tower rings back into place and check the fit. Once proper fit and location is confirmed, tack weld the upper and lower surfaces of each ring to the tower. Welding should not be performed with any wiring inside the tower, to avoid heat damage to the wire's insulation. Once the welding has cooled, remove any splatter which might have landed on the surfaces of the tower rings. Brush or spray the welded areas with a protective coating such as ZRC Cold Galvanizing Compound (or equivalent).



- Remove the welding alignment jig rods and store that kit for future use.
- Using the hole mark you made earlier, and ensuring that it is located on the North side of the tower, drill a hole for your cord grip or strain relief fitting. The diameter of the hole will depend upon the size of your specified electrical cable and your grounding wire, and the fitting you select. In most cases, the hole diameter need only be large enough

to permit the installation of the threaded or snap-in fitting (typically 1 inch). If using a threaded fitting, which is the most commonly accepted type, it may be necessary to tape the nut and a suitable wrench to a 4-foot extension pole with which you can reach the hole location from either the top of the tower section (for a 45-19HD) or the bottom of the tower section (for a 45-19).

In some cases, your AHJ may require a female fitting welded to the tower (as shown here) in which case the drilled hole diameter may be as large as 1 3/8 inches:



If a welded nipple is required by your AHJ, the solar tracker top cover should be slid into place between the welded rings and the nipple location before the nipple is welded into position.

This wire penetration hole, in the location/s described, is acceptable and will not affect your tower warranty. But, other holes (especially any in the bottom 5 feet of the tower) are not permitted.

TAPERED RING AND GEAR INSTALLATION

1. Disassemble the two shell assemblies by removing the 10 screws/washers that are located on both sides of the assemblies. Save hardware for later use. See Figure 1.

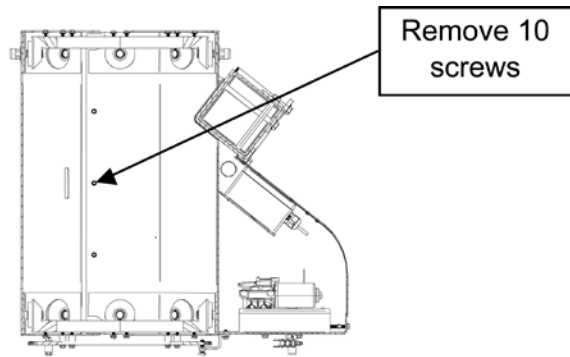

Figure 1

2. Install four of the eight tapered rings to the bottom-side of the upper tower ring. Use four 1/4"-20 X 7/8"L bolts, lock washers, and flat washers (from the tapered ring/gear mounting hardware) for each tapered ring. See Figure 2. After tightening, the four tapered rings should fit flush to each other without gaps.



Figure 2

3. Install the remaining four tapered rings to the top-side of the lower tower ring. Use 1/4"-20 X 7/8"L bolts, lock washers, and flat washers on the two ends of each Tapered Ring as shown in Figure 3. The middle two hole locations should be left vacant for now.
4. Install the two sun tracking gears to the bottom-side of the lower ring. Ensure the spacers on the gears are facing up. Use four 1/4"-20 X 1-3/4"L bolts, lock washers, and flat washers for each gear. See Figure 3.

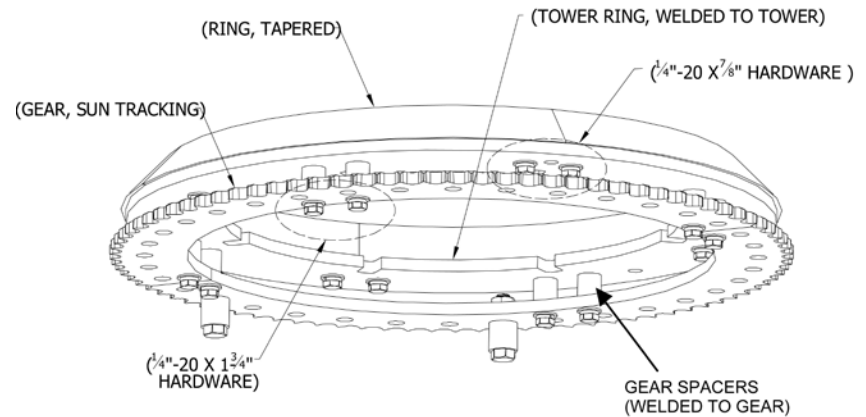

Figure 3

SUPPORT SHELL INSTALLATION

- On each of the three top tapered rollers on the sun side support shell assembly, loosen the jamb nut and adjust the tapered roller axle until the tapered rollers are against the frame. Hand-tighten the jamb nuts.
- Carefully lift the assembly onto the tower (ensure the assembly is oriented with the adjustable rollers toward the top of the tower). Using the two slots provided, temporarily strap the assembly to the tower (be sure to keep the ratchet for the strap on the outside of the assembly for easy removal. See Figure 4.



Figure 4

- Loosely re-insert a 5/16"-18 X 3/4" screw (no washers) into the center hole on each side of the cross arm side support shell assembly. This will help guide the assemblies into alignment.
- Adjust the tapered rollers on the cross arm side support shell assembly until they are against the frame.
- Lift the assembly onto the tower (ensure the assembly is oriented with the adjustable rollers toward the top of the tower). Connect the shell assemblies by inserting and tightening the remaining 5/16"-18 screws, lock washers and flat washers. Reinstall the two center screws with flat and lock washers. See Figure 5.

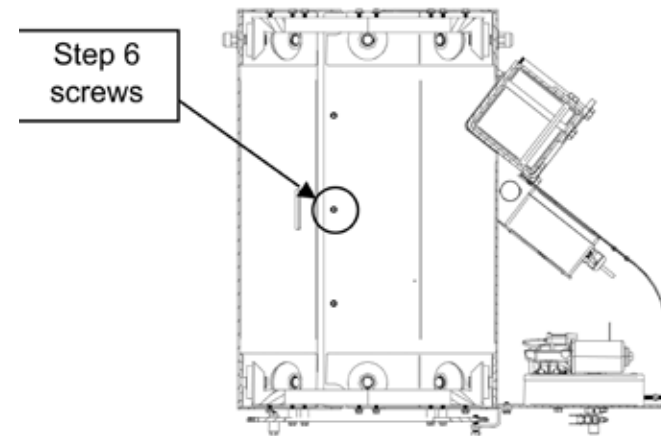

Figure 5

- Remove the temporary strap from the sun side support shell assembly.

11. Adjust the top eight (8) tapered rollers by loosening the jamb nuts, and adjusting the threaded axles. Adjust the tapered rollers such that the threaded axles protrude the same distance from the frame. See Figure 6. There should be minimal play between the shell assembly and the tower after tightening. If too much play still exists, re-adjust all rollers the same amount. Tighten the jamb nuts once all rollers are adjusted. Confirm the shell assemblies roll freely around the tower.

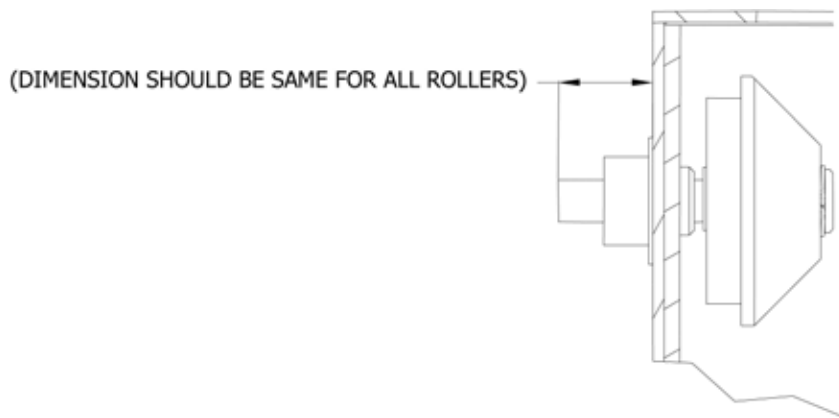

Figure 6

12. Install the hard stop bracket using the parts in the hard stop hardware package. Attach the bracket to the bottom of the frame as shown in Figure 7. Use two $\frac{1}{4}$ "-20 X $\frac{3}{4}$ " bolts, flat washers and lock washers.

NOTE: The $\frac{3}{8}$ "-16 X 1-1/4" stop-bolt can be used during assembly or maintenance to lock the tracker in place.

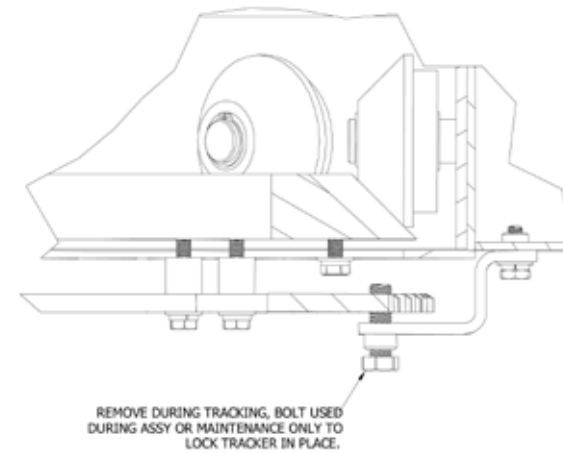

Figure 7

CROSS ARM STRUCTURE ASSEMBLY AND INSTALLATION

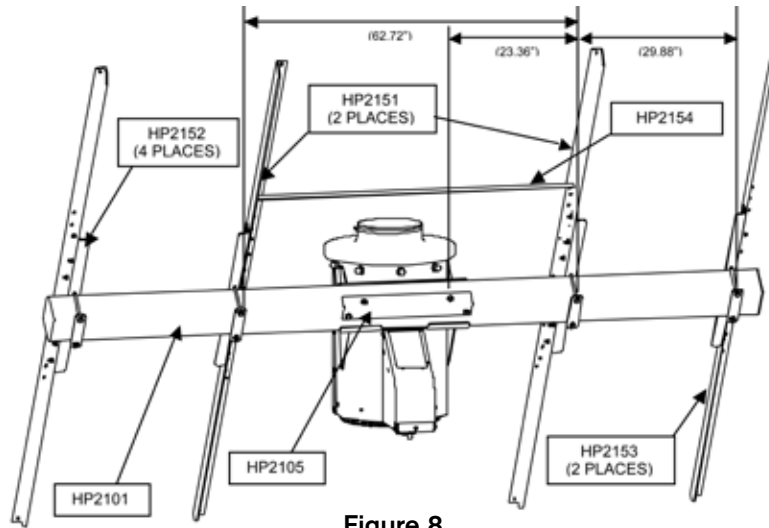

Figure 8

13. Center the 6" X 6" cross arm tube onto the cross arm side support shell assembly. Ensure the hole pattern on the cross arm tube lines up with the hole pattern on the support shell assembly. Install the beam clamp bracket on the cross arm tube using four 1/2"-13 bolts, flat washers, lock washers and hex nuts from the cross arm mounting hardware package. See Figures 8 & 9.

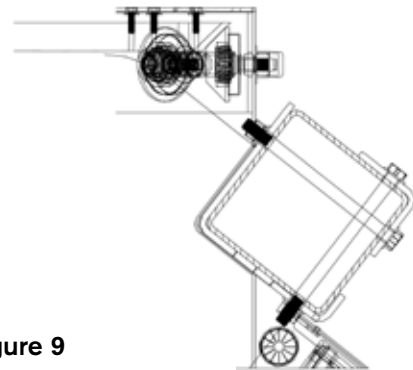

Figure 9

14. Install the four cross arm/wing mounting brackets onto the cross arm tube using the 1/2"-13 X 7-1/2" bolts, flat washers, lock washers, and hex nuts with the cross arm/wing mounting plates. The brackets should be located and oriented as shown in Figure 8 (dimensions shown are for Motech 235W solar panels). Temporarily leave the bolts loose.
15. Install the two solar panel/inverter support rails onto the mounting brackets closest to the sun tracker assembly. Ensure the rails are oriented as shown in Figure 8. Attach using seven 3/8"-16 X 1-1/4" bolts, flat washers and nuts on each rail.
16. Attach the cable support to the rails using 5/16" X 7/8" bolts, flat washers, lock washers and hex nuts. See Figure 8. Once installed, verify the location of the cross arm/wing mounting brackets and tighten the 1/2"-13 X 7-1/2" bolts for the two inner rails that were left loose in Step 14.
17. Install the two solar panel support rails onto the mounting brackets furthest from the sun tracker assembly. Ensure the rails are oriented as shown in Figure 8. Attach using seven 3/8"-16 X 1-1/4" bolts, flat washers and nuts on each rail. Leave the remaining 1/2"-13 X 7-1/2" bolts loose until the solar panels have been installed.

MOTOR/GEARBOX INSTALLATION

18. Remove the enclosure cover by removing the two cover bolts. Place the motor/gearbox in the enclosure as shown in Figure 10. Loosely insert the four 5/16"-18 X 5/8" bolts, flat washers and lock washers from the motor/gearbox hardware. Install the chain tensioning bolt (5/16"-18 X 2-1/4") and flat washer (do not tighten).

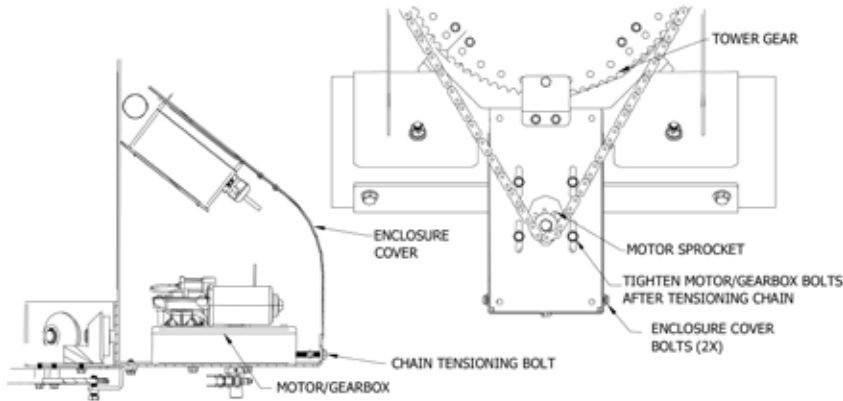

Figure 10

19. The solar tracker top cover must be slid into place and installed prior to installing the Skystream 3.7™ onto the top of the tower. Once the turbine is installed, it will not be possible to slide the solar tracker top cover into position. After sliding the top cover into position, above the upper welded ring but below the wire penetration hole or welded nipple (if used), it can be left loose until final assembly of the solar tracker. After fully assembling and orienting the solar tracker, the top cover should be slid downwards and the stainless steel band clamp should be tightened to keep it in position. The cover's perimeter edge lip, facing downwards, should overlap the top edge of the solar tracker assembly approximately 1/2 inch.

ALIGNMENT AND CHAIN INSTALLATION

19. Prior to installing the chain, the solar panels must be facing true South (if in the Northern Hemisphere) prior to power-up. True South differs from magnetic South. In order to find true South, the magnetic declination for the installation location must be found. The magnetic declination value represents the error between magnetic North and True North for a specific location. This value can be represented as an easterly (positive (+)) declination, or a westerly (negative (-)) declination. There are two ways to find the magnetic declination:

1. Go to: <http://www.ngdc.noaa.gov/geomagmodels/Declination.jsp>, enter the zip code for the installation location and click "Get Location." Then click "Compute Declination" and find the declination in the lower box.
2. Looking at the following chart, use the blue and red lines to find the approximate magnetic declination for the installation location. These values vary slightly from year to year, but this chart is sufficient for an approximate value.

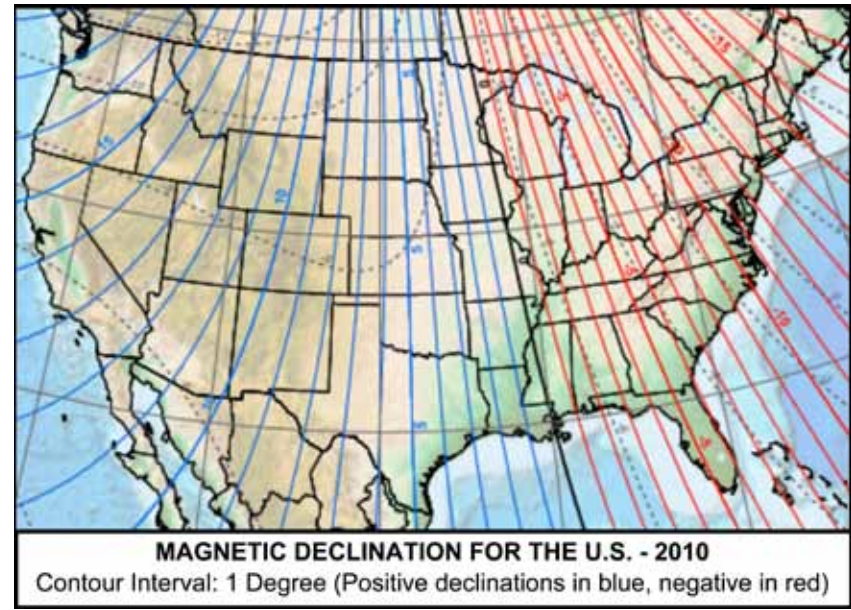

- Using a compass, find magnetic North. Adjust the compass by the magnetic declination value (while the needle stays at magnetic North, rotate the compass counter-clockwise for easterly (+) declinations, and clockwise for westerly (-) declinations. See Figure 11.

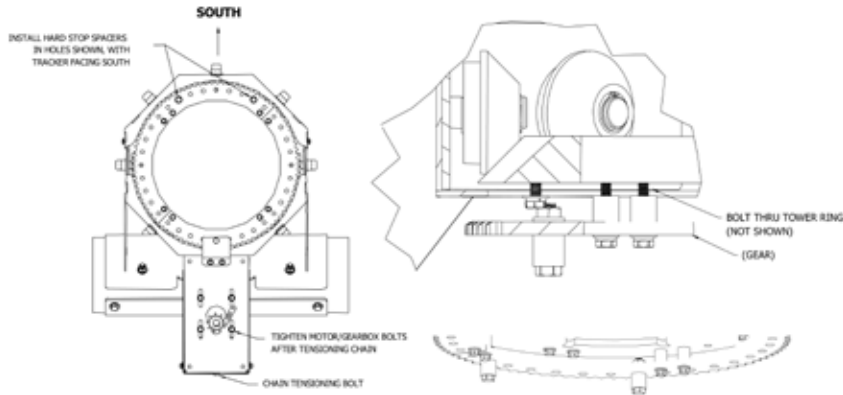

Figure 12

- Install two spacers, 3/8"-16 X 1-1/2" bolts, and hex flange lock nuts (from the hard stop hardware package) on the tower gear in the locations shown. See Figure 12.
- Install the chain around the tower gear and motor sprocket by installing the master link and attaching the clip. See Figure 10.
- Ensure the assembly is still aligned with true South, and tighten chain tension. Check that chain play is similar on both sides of the sprocket. Once desired tension is reached, tighten the four motor/gearbox bolts located underneath the frame assembly to lock in place. See Figure 10.
- Install the sun tracker cover assembly to the tower, above the sun tracker assembly. Tighten using the pipe clamp, and install the two screws.

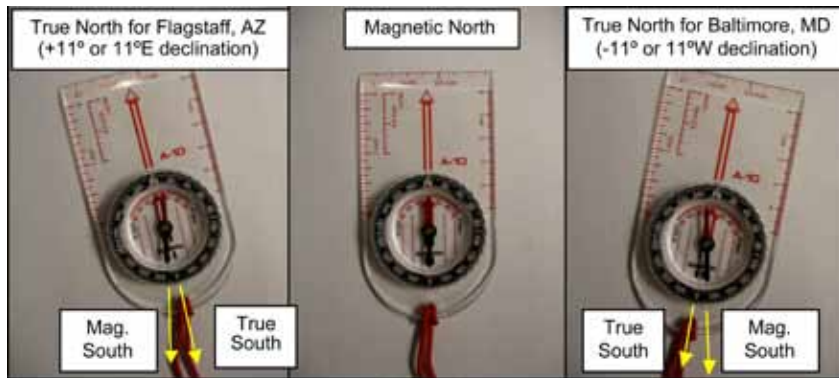

Figure 11

- Rotate the sun tracker assembly until the solar panels are facing true South (180° from true North).

SOLAR PANEL AND MICRO-INVERTER INSTALLATION

Component configuration/layout should, normally, meet the specifications of this reference diagram – as always, however, your local AHJ may modify these or may impose additional requirements:

1. Using the mounting brackets supplied with the six micro-inverters, mount them onto the solar panel/inverter support rails using the 5/16"-18 X 3/4" hardware as shown here. Also, see Figures 13 & 14.

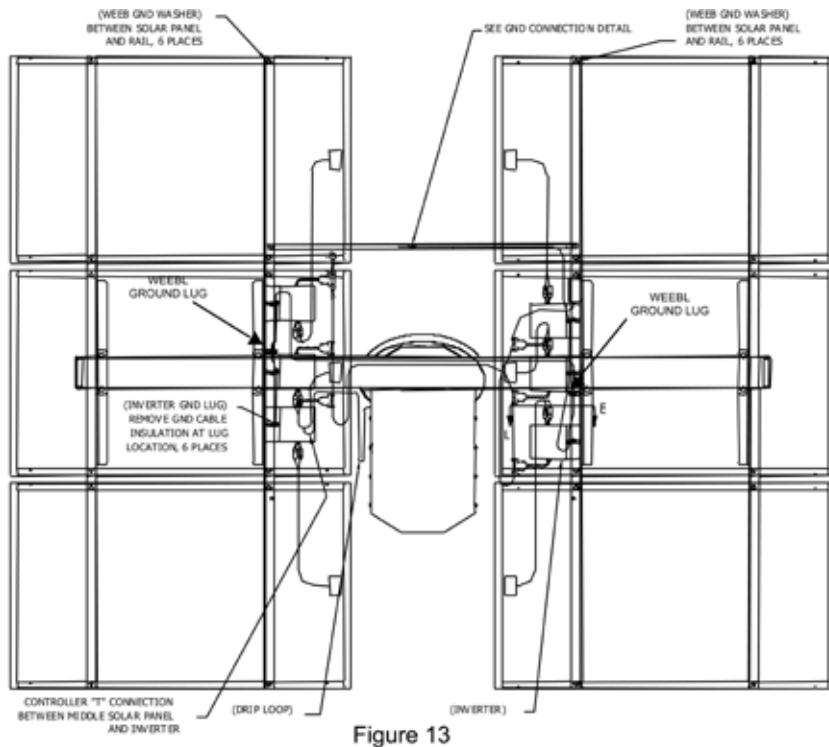

- Attach six solar panels to support rails as shown. Rails may need to be adjusted depending on solar panel mounting hole locations. To meet the requirements of the NEC article 690.43 (and the referenced articles 250.134 or 250.136(A)), either WEEB Ground Washers or a ground conductor or both (as required by your local AHJ and permitting/inspection officials) must be used as well. Tighten all solar panel and rail hardware when panels and rails are in the correct positions. See Figures 13 & 14.

The PV modules which came with your Skystream Hybrid 6™, and the included Enphase micro-inverters, all have compatible Tyco Solarlok connectors. The PV module connectors simply plug into the Enphase micro-inverter input connectors.

Install the two WEEBL ground lugs to the rails in the locations shown, and route the ground cable (#6 AWG) as shown. See Figures 13 & 14 (detail A).

- Connect and route the Enphase AC micro-inverter cable as shown in Figure 13. Terminate the cable end with the Enphase branch terminator.

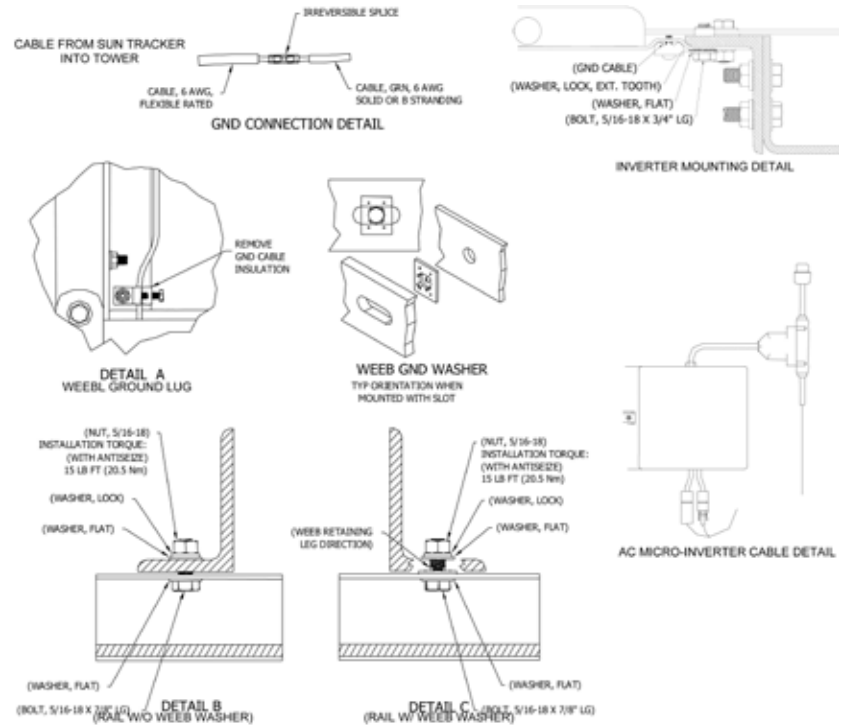
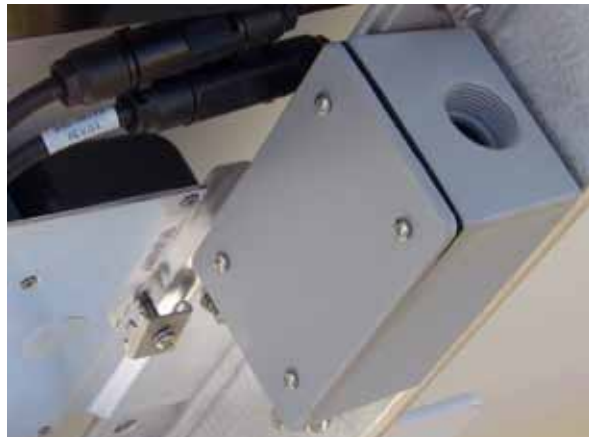

Figure 14

- Mount a water resistant single gang junction box to use for the AC connection from the Enphase Engage AC cable to the dntower AC cable (which passes through the fitting you installed in the tower). The junction box should be mounted to one of the solar panel support rails. The size and type of box will vary depending upon local requirements, but a typical installation includes a readily-available single-gang box as shown here:

- Included in the system kit is a suitable length of Enphase Engage cable, which has connection points for the micro-inverter grid connections. One end of the cable will be capped with a weatherproof cap, using the included cable termination kit. See the applicable Enphase instructions, included with the inverters and cable kit, for details on how to cut and terminate the cable



FINAL CABLE CONNECTIONS

- Connect solar panels to the appropriate micro-inverters. Connect the tracker controller “T” connections between the middle solar panel and the micro-inverter. See Figure 13. Ensure a drip loop is provided where cables enter the sun tracker shell.
- Secure all cables using cable ties where appropriate.
- Run a ground cable and an AC cable through the strain relief or fitting to the base of the pole. Make connections in the base of the pole.

A normal new installation will have a sub-panel at the base of the tower, so that the Skystream 3.7™ turbine-to-sub-panel wire run is no longer than 55 feet. In this case, the Skystream 3.7™ wiring can be #10 AWG or #8 AWG and of a type required by local codes. The wiring from the PV inverter junction box (mounted on the solar tracker) to the sub-panel can be #12 AWG and of a type required by local codes.

The sub-panel at the tower base will contain two double-pole breakers. The Skystream 3.7™ circuit is protected by a 20A breaker and the PV circuit is protected by a 15A breaker.

The copper conductors between the sub-panel and the main panel connection point should be sized, at a minimum, based on the following chart:

This recommendation is based on the ac/dc resistance or impedance from NEC 2011 Tables 8 and 9 for stranded conductors operating on a DC or AC 60Hz system. The ampacity of each conductor size is based on NEC 2011 Table 310.15(B)(16) for 60C-90C insulated conductors rated 0 through 2000 volts with not more than three current carrying conductors in conduit, raceway, cable or earth with an ambient temperature of 30C (86F). Calculations are based on a maximum allowable voltage drop of 2%.

Gauge	Length in feet (max)
#10	120
#8	190
#6	310
#4	470
#2	745
#1	920
#1/0	1120

4. Make the connections at the system disconnect, optional meter, and at the main panel connection point (circuit to be protected by a 40A double pole breaker).
5. Remove Stop Screw if installed.
6. Re-install the enclosure cover and cover bolts that were removed in Step 18.
7. Ensure the tracker controller switch is in the "OFF" position, and connect the motor cable to the connector coming from the control enclosure. Turn the switch to the "ON" position.

CAUTION – MOTION: The controller super-capacitors will begin to charge up once the solar panels are connected to the controller. After the controller switch is turned "ON" and a GPS signal is acquired, the controller calculates the sun position, and tracking will begin. Tracking motion occurs on the 10-minute mark. (The tracker will return to South at low power conditions. (AC does not have to be connected for tracker operation).

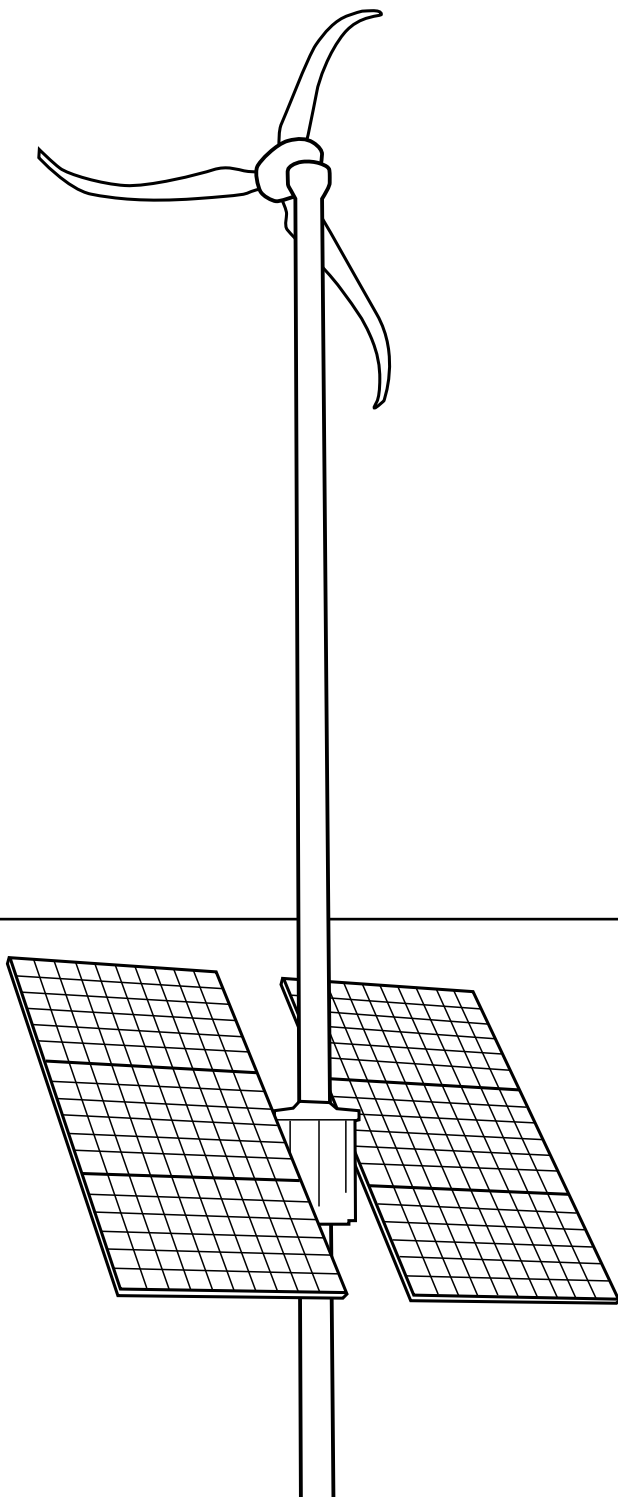

SKYSTREAM HYBRID 6™

APPENDIX A: ELECTRICAL DIAGRAMS

Southwest Windpower, Inc.
1801 West Route 66
Flagstaff, Arizona 86001
Phone: ++ (1) 928 - 779 - 9463
Fax: ++ (1) 928 - 779 - 1485

www.windenergy.com



MADE IN THE **USA** © January 2012 Southwest Windpower, Inc.
Inc.
All Rights Reserved

Skystream Hybrid 6™ Installation Manual

Appendix A: Electrical Diagrams

- 1) **GRID CONNECTION OPTION A:**
120/240 V, 60 Hz, Split Phase, Sub-panel at Tower Base _____ **3**

Fig. 1. Grid Connection Option A: 120/240 V, 60 Hz, Split Phase, Sub-panel at Tower Base

